

PHYSICAL SPECIFICATION

Nominal Voltage		2V
Nominal Capacity (10HR)		800Ah
Dimension	Length	191±2mm (7.52 inches)
	Width	210±2mm (8.27 inches)
	Container Height	646±2mm (25.43 inches)
	Total Height	701±2mm (27.60 inches)
Weight		Approx. 64 Kg (141.1lbs)
Standard Terminal		Bolt-and-nuts terminal Bolt Type: M8

Unit: mm

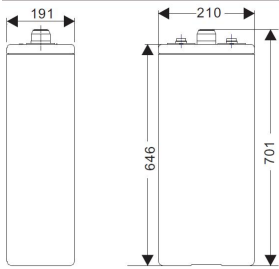
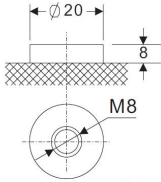

ELECTRICAL SPECIFICATION

Characteristics			Main Advantages
Capacity	20 hour rate (47.0A to 1.80V/cell) 10 hour rate (80.0A to 1.80V/cell) 5 hour rate (136.6A to 1.75V/cell) 1hour rate (458.8A to 1.60V/cell)	940.0Ah 800.0Ah 683.0Ah 458.8Ah	>> adopt tubular positive plate >> longest lifespan under deep discharge >> Strong temperature resistance performance >> Better charge reception capability >> 20 years design life
Operating Temp. Range	Discharge : -20°C~55°C Charge : -10°C~45°C Storage : -15°C~45°C		
Max. Discharge Current	4000A(5sec)		
Short Circuit Current	7300A		
Designed life	20 years (floating) at 25°C(77 °F)		
Internal Resistance	Full charged battery (25°C,77 °F) 0.31mΩ		
Constant Voltage Charge	Cycle	Initial Charging Current less than :≤200A Voltage: 2.35~2.40V at 25°C (77 °F) Temperature Coefficient -5mV/°C	
	Standby	No limit on Initial Charging Current Voltage: 2.23V at 25°C (77 °F) Temperature Coefficient -3mV/°C	

CONSTANT CURRENT DISCHARGE RATING A@25°C

F.V/TIME	30min	1h	2h	3h	4h	5h	8h	10h	24h
1.60V	674	462	288	207	165	142	102.0	84.9	37.76
1.65V	652	451	282	204	164	141	101.3	84.4	37.72
1.70V	624	437	275	201	161	139	100.1	84.0	37.36
1.75V	601	424	268	196	158	137	98.2	82.8	36.72
1.80V	550	404	258	193	155	134	95.8	80.2	35.84
1.85V	488	375	244	186	150	129	93.0	79.2	34.72

CONSTANT POWER DISCHARGE RATING WATT PER CELL@25°C

F.V/TIME	30min	1h	2h	3h	4h	5h	8h	10h	24h
1.60V	1229	850	531	384	306	264	189.7	157.8	70.48
1.65V	1199	832	520	378	303	262	188.2	157.1	70.32
1.70V	1152	808	509	374	300	258	185.8	156.2	69.52
1.75V	1112	789	498	366	295	254	183.3	154.8	68.96
1.80V	1026	761	486	363	294	253	181.8	152.1	68.08
1.85V	928	712	466	356	288	248	178.6	151.4	67.28

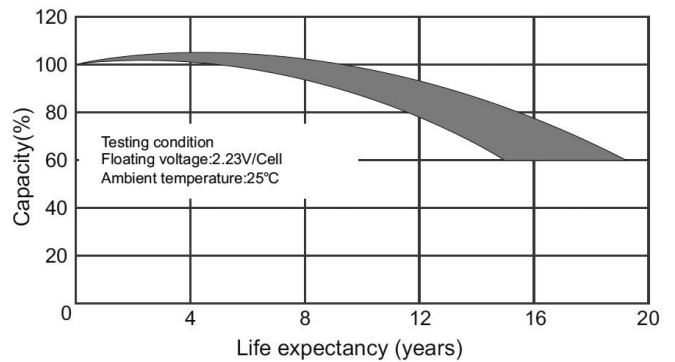
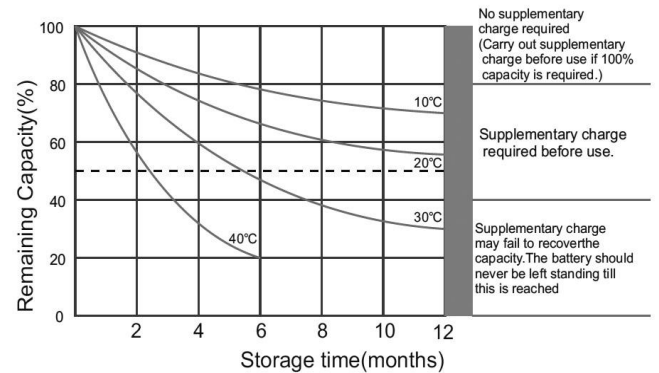
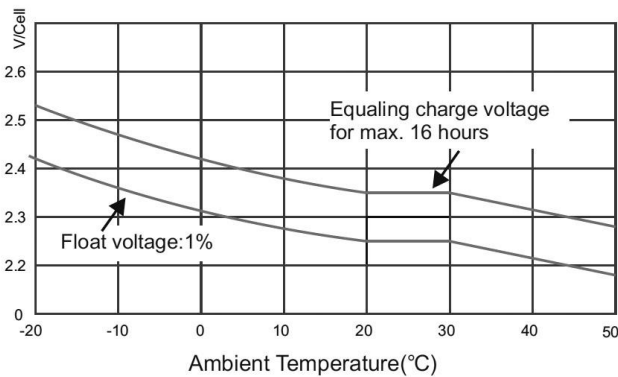
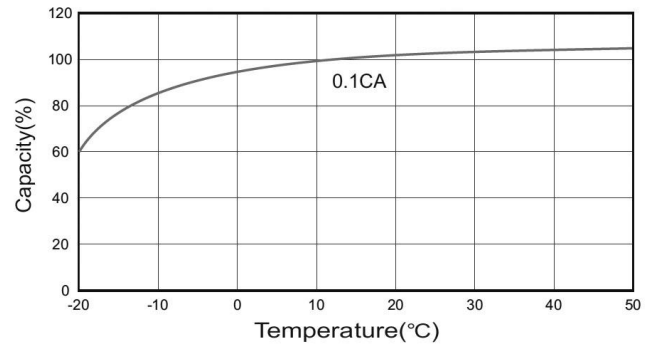
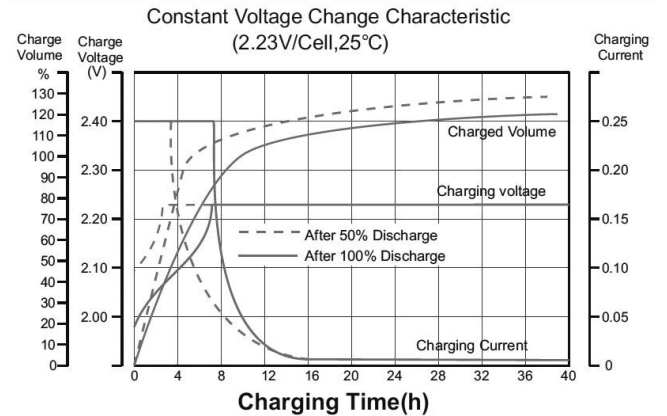

(Note) All above information shall be changed without prior notice, Shimastu reserves the right to explain and update the latest information.